



2002 Heavy Setup Sheet

1 13/16" Spacer (Setup Kit)

3/4" Square Tube (Setup Kit)

Left Front Tire	Dunlop R6 4.5x5x10
Wheels	2" x 3"
Circumference	31"
Tire Air Pressure	10 lbs
Weight	
Tire Center To Frame Edge	5 1/4"
Ride Height	8 1/8"
Shock / Spring #	3/95
Air Shock Pressure	30 lbs

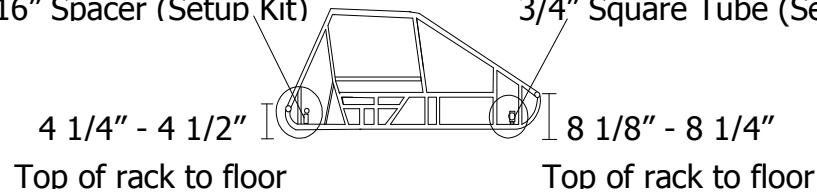

Right Front Tire	Dunlop DBS 11x5x6
Wheels	4" x 2"
Circumference	33 1/2"
Tire Air Pressure	10 lbs
Weight	
Tire Center To Frame Edge	11 1/2"
Ride Height	8 1/8"
Shock / Spring #	5/135
Air Shock Pressure	30 lbs



Panhard Bar

SWB Axle 7 3/4—7 7/8

Left Rear Tire	Dunlop R6 or DBS 4.5x5x10
Wheels	4" x 2"
Circumference	31-31 1/2"
Tire Air Pressure	7 lbs
Weight	12-16 lbs
Tire Center To Frame Edge	5-5 1/2"
Ride Height	4 1/4-4 1/2"
Shock / Spring #	3/155or165
Air Shock Pressure	30 lbs

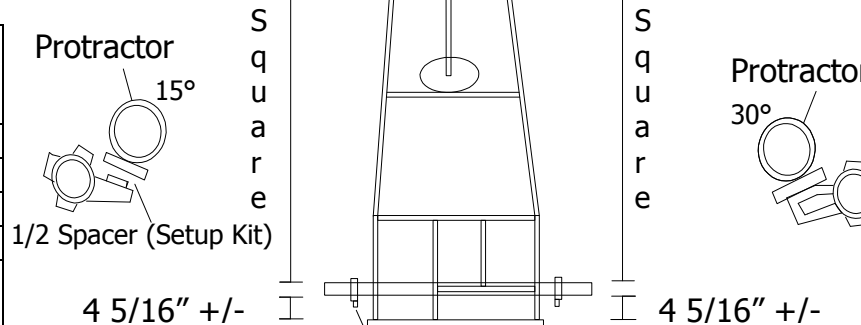

Birdcaae flush with bottom rail



Panhard Bar

Right Front Tire	Dunlop DBS 11.5x7.10x6
Wheels	3 1/2" x 5"
Circumference	34 1/2-35"
Tire Air Pressure	10 lbs
Weight	
Tire Center To Frame Edge	11-11 1/2"
Ride Height	4 1/4-4 1/2"
Shock / Spring #	3/145
Air Shock Pressure	30 lbs

GT American Race Cars
Phone 510.657.5054
Fax 407.290.8458

WWW.GTAMERICAN.COM

Tech Support
gtsupport@bellsouth.net
Advertising/Financing/Website
jannamoslow@bellsouth.net